

# Heat Engine/Gas Law Apparatus

TD-8572A

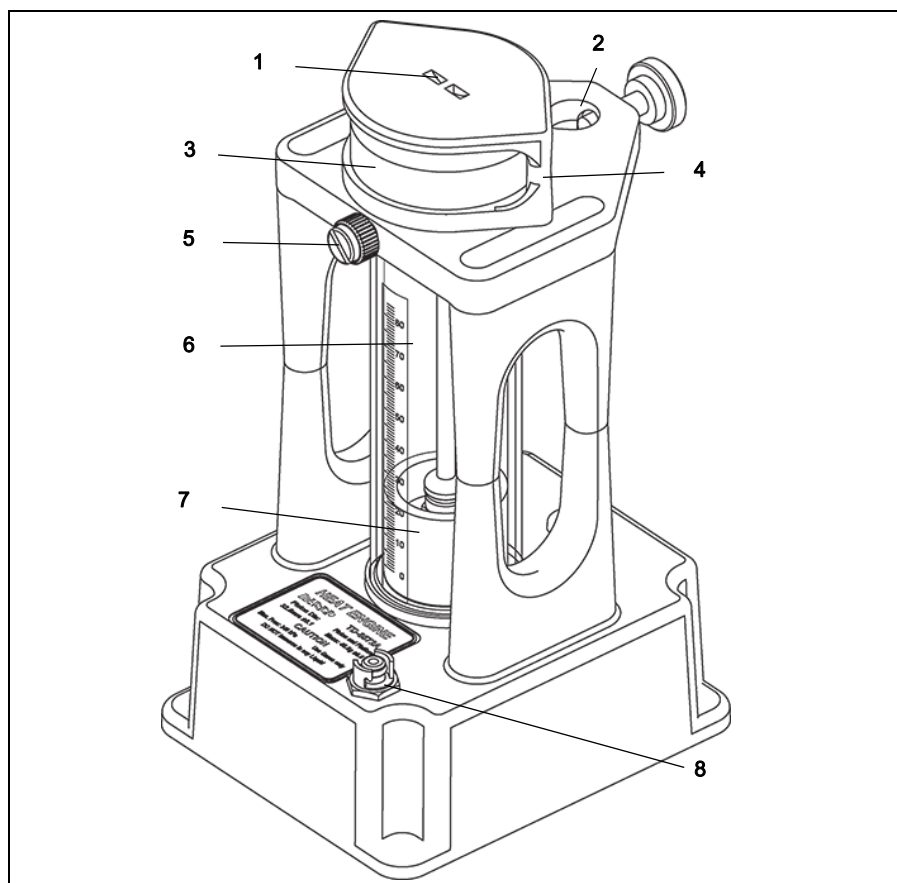

TD-8572A Features	TD-8572A Features
1. String Attachment Point	5. Locking Screw
2. Rod Clamp Mount	6. Precision-bore Pyrex Cylinder
3. 200 gram Mass	7. Ultra-low Friction Graphite Piston
4. Mass Platform	8. Quick-release Connector Port (male)

## Introduction

The PASCO TD-8572 Heat Engine/Gas Law Apparatus is used for quantitative experiments involving the Gas Laws and for investigations of a working heat engine. A heat engine is a device that does work by extracting thermal energy from a hot reservoir and exhausting thermal energy to a cold reservoir. The heat engine consists of air inside a cylinder. The air expands when the cylinder is immersed in hot water. The expanding air pushes on a piston and does work by lifting a weight. The apparatus can be used to measure the amount of work done by thermal energy, also known as thermodynamic work.

The Heat Engine/Gas Law Apparatus can be used to confirm various gas laws such as Charles' Law (at constant pressure, the volume of a fixed mass of gas varies directly with the absolute temperature), Boyle's Law (the product of the volume of a gas and the pressure of the gas is constant at a fixed temperature), and the Combined Gas Law (for a given mass of gas, if volume is held constant, pressure is proportional to absolute temperature).

The heart of this apparatus is a nearly friction-free piston/cylinder system. The graphite piston fits snugly into a precision-ground Pyrex cylinder so that the system produces almost friction-free motion and negligible leakage.

### Heat Engine/Gas Law Apparatus Accessory Kit

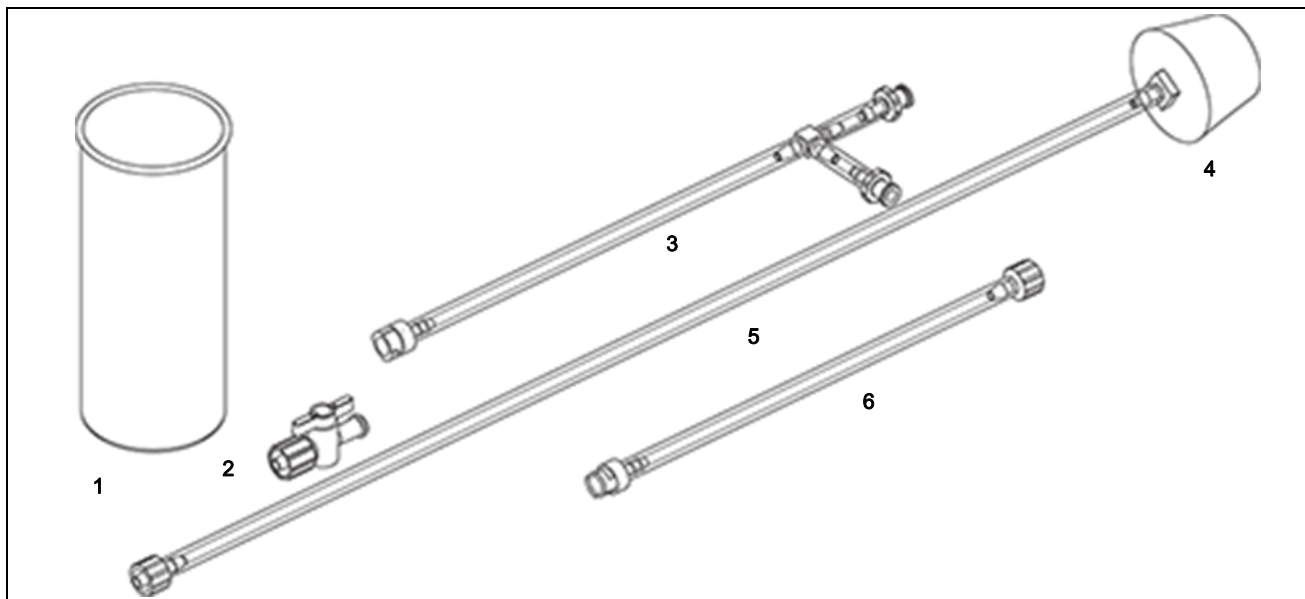

Included Items	Included Items
1. Thermal Can	2. Stopcock Valve
3. Main Connector Tubing	4. #10 One-hole Rubber Stopper
5. Rubber Stopper Tubing	6. PASPORT Pressure Sensor Adapter Tubing

Recommended Items	Description
PASCO Interface and Data Collection Software*	
PASPORT Dual Pressure Sensor or PASCO Wireless Pressure Sensor*	
PASPORT Quad Temperature Sensor or PASCO Wireless Temperature Sensors (2)*	
PASPORT Rotary Motion Sensor or PASPORT Motion Sensor*	
Large Rod Stand	ME-8735
Steel Rod, 90 cm	ME-8738
Mass and Hanger Set	ME-8979
Plastic Containers (set of 2)	ME-7559
Thread (3 pack)	ME-9875

\*See [www.pasco.com](http://www.pasco.com) for more information

The PASPORT Dual Pressure Sensor (PS-2181) is recommended because of its ranges: 0 to 200 kPa (absolute and  $\pm 100$  kPa (relative)) and its resolution (0.01 kPa). The PASPORT Quad Temperature Sensor (PS-2143) is recommended because of its range ( $-35$  to  $135^{\circ}\text{C}$ ), its resolution ( $\pm 0.5^{\circ}\text{C}$ ), and its included equipment: two Stainless Steel Temperature Probes (PS-2153), and three Fast Response Temperature Probes (PS-2135).

## Included Items

**Thermal Can:** This is the cylinder that contains the air.

**Stopcock Valve:** This valve has a male Luer barb on one end and a female Luer barb on the other end. It is used when the Main Connector Tubing and Rubber Stopper Tubing are connected, and you want to cap the remaining unconnected side female Luer barb. The valve is closed when the handle is at right angles to the body. The male Luer barb connects to the side female Luer barb on the Main Connector Tubing.

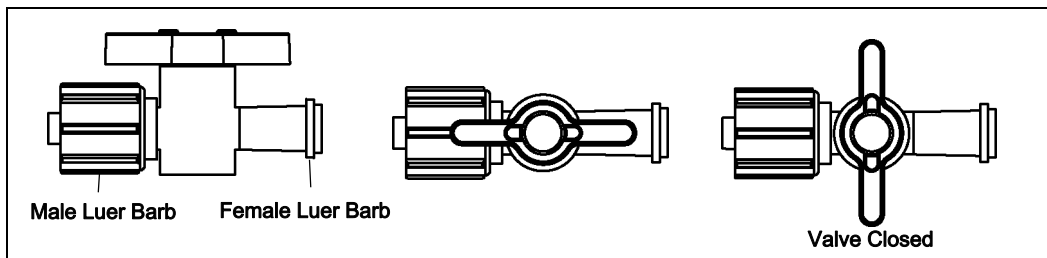

**Main Connector Tubing:** This section has a quick-release connector at one end that fits on the quick-release connector port (male) on the base of the Heat Engine. Put the quick-release connector on the port, and then turn the connector slightly clockwise to lock it in place. The Main Connector Tubing has a “Tee” section with two female Luer barbs, one at the end and one on the side. The barb at the end of the tubing connects to the Rubber Stopper Tubing, and the side barb can connect to the PASPORT Pressure Sensor Adapter Tubing, the Stopcock Valve, or other male Luer barb connector.

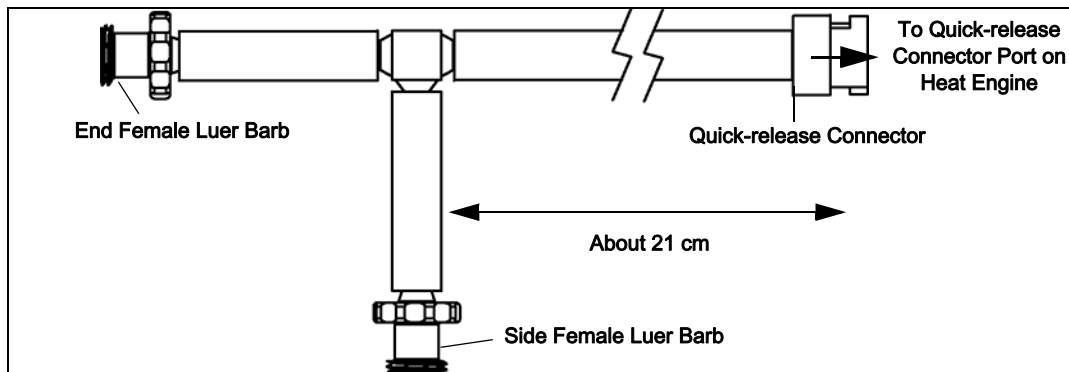

**#10 One-hole Rubber Stopper:** This fits into the top of the Thermal Can.

**Rubber Stopper Tubing:** The male Luer barb connects to the end female Luer barb on the Main Connector Tubing.

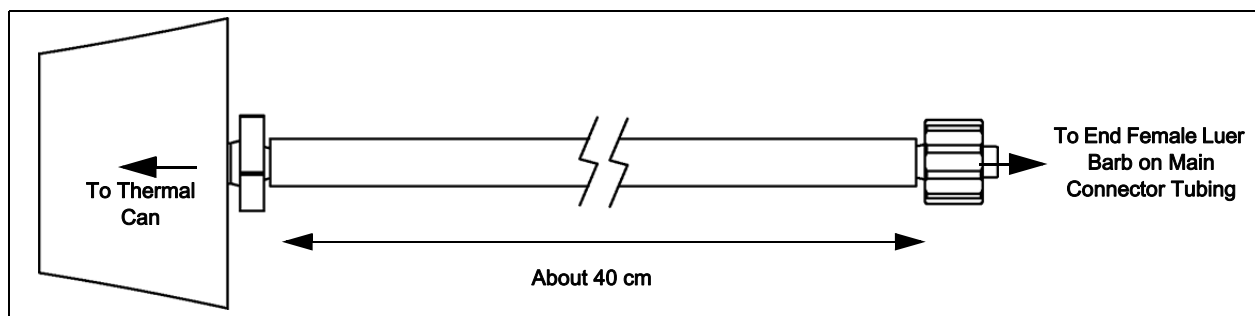

PASPORT Pressure Sensor Adapter Tubing: The male Luer barb on one end of the tubing connects to the side female Luer barb on the Main Connector Tubing. The quick-release connector on the other end of the tubing connects to a quick-release connector port on a PASPORT pressure sensor.

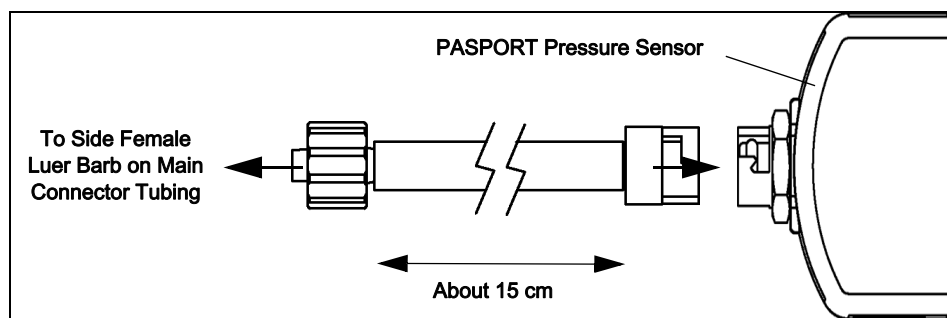

### Wireless Pressure Sensor

If you want to use the Wireless Pressure Sensor, then make an adapter tube with the male Luer barbs and tubing that are included with the wireless sensor. Connect one end to the sensor. Connect the other to the side female Luer barb on the Main Connector Tubing.

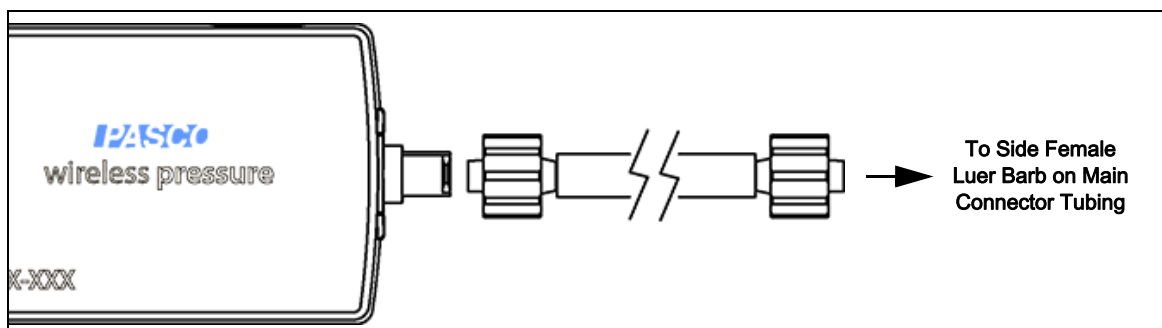

## Demonstration: Heat Engine

Equipment Needed	
Heat Engine/Gas Law Apparatus	Container of hot water
200 gram mass	Container of ice water

### Introduction

Use the Heat Engine/Gas Law Apparatus to demonstrate the basic principle of a heat engine. The air in a cylinder expands when the cylinder is immersed in hot water. The expanding air pushes on a piston and does work by lifting a weight. When the cylinder is immersed in cold water, the air in the cylinder contracts. The contracting air allows the piston and weight to drop. The bullet list below uses overrides to make it more compact.

### Equipment Setup

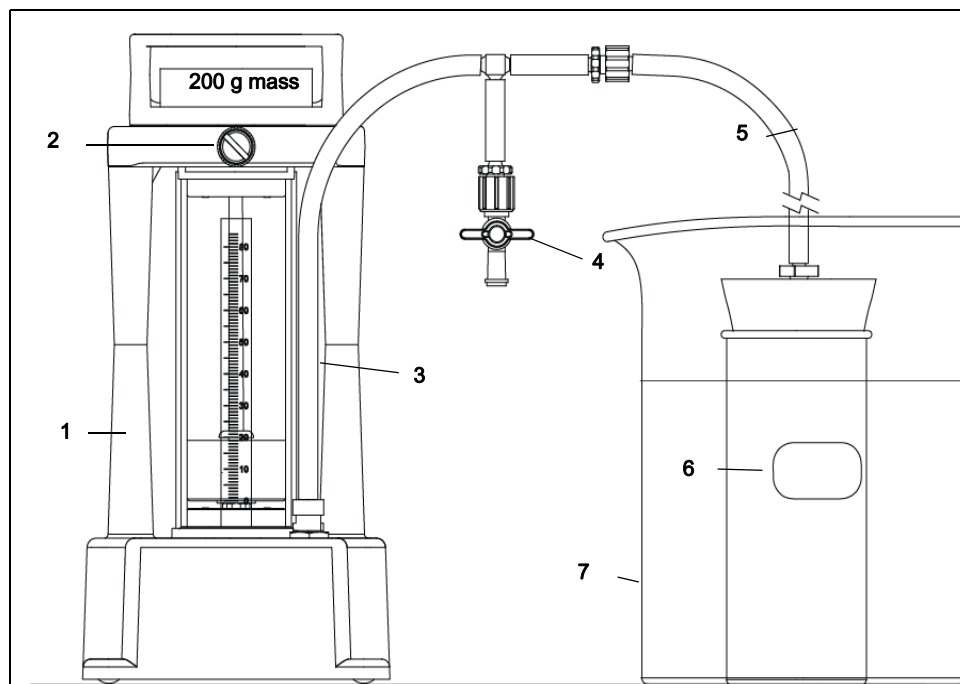

Setup Items	Setup Items
1. Heat Engine/Gas Law Apparatus	2. Locking Screw
3. Main Connector Tubing	4. Stopcock Valve
5. Rubber Stopper Tubing and Stopper	6. Thermal Can
7. Container (one of two)	

1. Attach the main connector tubing to the quick-release connector port on the Heat Engine. Add the stopcock valve (with the valve closed) to the side female Luer barb.
2. Connect the rubber stopper tubing to the end female Luer barb on the main connector tubing. Push the rubber stopper firmly into the thermal can.

3. Make sure that the locking screw on the Heat Engine is loose. Put the 200 gram mass into the mass platform on the Heat Engine.
4. Prepare a container of hot water (about 80°C) and a container of ice water.

### Procedure

1. Immerse the thermal can into the container of hot water.
  - Note that the piston rises as the air in the can warms up.
2. Move the thermal can from the hot water to the container of ice water.
  - Note that the piston drops as the air in the can cools down.

### Questions

1. Why does the piston rise when the thermal can is in the hot water?
2. Why does the piston drop when the thermal can is in the ice water?

## Experiment 1: Charles' Law

Equipment Needed	
Heat Engine/Gas Law Apparatus	Container of hot water
PASCO Interface and Data Collection Software	Ice
PASCO Temperature Sensor	

### Introduction

Charles' Law states that at a constant pressure, the volume of a fixed mass or quantity of gas varies directly with the absolute temperature.

$$V = cT$$

In the formula,  $V$  is volume,  $T$  is absolute temperature measured in Kelvin, and  $c$  is a constant.

### Equipment Setup

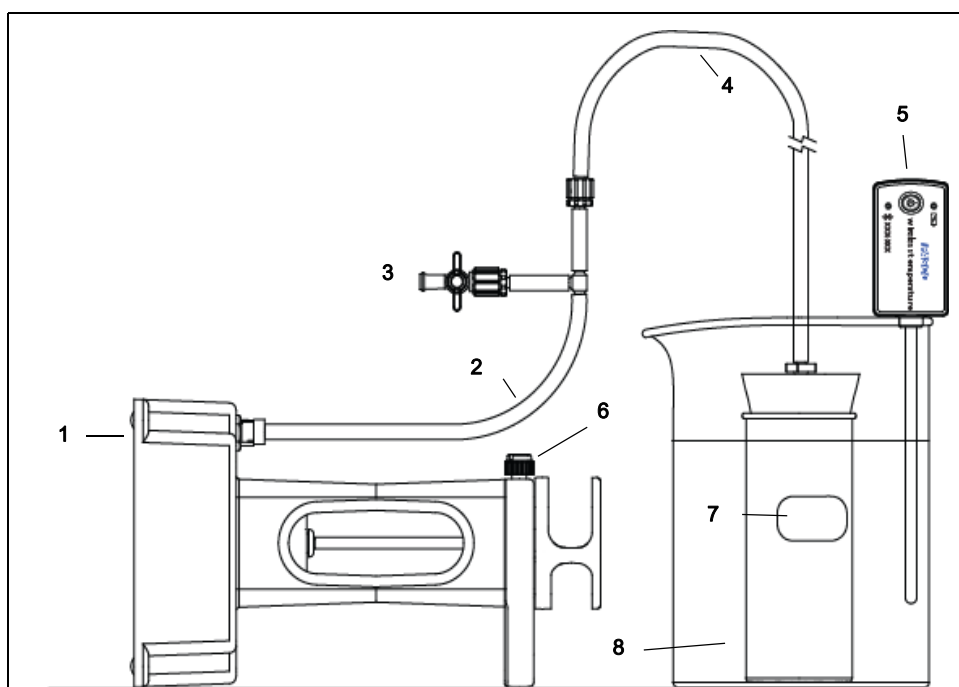

Setup Items	Setup Items
1. Heat Engine/Gas Law Apparatus	2. Main Connector Tubing
3. Stopcock Valve (valve closed)	4. Rubber Stopper Tubing and Stopper
5. PASCO Temperature Sensor	6. Locking Screw
7. Thermal Can	8. Container with hot water

1. Remove the thumbscrew from the rod clamp mount. Place the Heat Engine on its side so that the cylinder is horizontal. Loosen the locking screw so that the piston can move freely in and out. Start with the piston at the bottom-most position (at 0 millimeters).
  - In the horizontal position, the force acting on the mass platform of the Heat Engine is atmospheric pressure and is constant throughout the range of motion of the piston (from 0 to about 75 mm). You can record the position of the piston using the metric scale on the side of the cylinder.
2. Attach the main connector tubing to the quick-release connector port on the Heat Engine. Add the stopcock valve to the side female Luer barb. Close the valve on the stopcock.
3. Attach the rubber stopper tubing to the end female Luer barb on the main tubing. Put the rubber stopper firmly into the thermal can.
4. Connect a PASCO Temperature Sensor to a computing device.
5. Prepare a container of hot water (about 80°C). Put the sensor probe into the hot water, but do not let the tip of the probe touch the bottom of the container.

### Software Setup and Data Collection

For information about collecting, recording, displaying and analyzing data, refer to the User's Guide or Online Help System for the data collection software.

1. Start the PASCO data collection software and set up a display to watch the temperature.
2. Prepare to record temperature and the position of the piston. NOTE: The volume in the cylinder depends on the piston position and the surface area of the piston. The piston's diameter is 32.5 millimeters.
3. Place the thermal can into the container of hot water. After the piston has been pushed to its farthest position by the expanding air from the thermal can, record the temperature and the position of the piston.
4. Add ice to the container. Record the temperature and piston position at regular time intervals as the water cools.
5. Stop recording data when the piston does not move anymore (or the water temperature reaches 0°C).

### Data and Calculations

Temperature °C	Temperature K	Position mm	Volume mm <sup>3</sup>

1. Calculate and record the temperatures in degrees kelvin.
2. Calculate the volume in cubic millimeters for each piston position you recorded. Remember that the volume in a cylinder is the area of the base of the cylinder multiplied by the height of the cylinder. In this case, the area of the base of the cylinder is the area of the piston, and the height of the cylinder is the piston position.

**Analysis**

Determine whether the slope of the plot of temperature versus volume is linear.

**Question**

How well does your graph of temperature versus volume support the idea that volume of a gas at constant pressure is directly proportional to the absolute temperature of the gas?



## Experiment 2: Boyle's Law

Equipment Needed	
Heat Engine/Gas Law Apparatus	PASCO Pressure Sensor
PASCO Interface and Data Collection Software	

### Introduction

Boyle's Law states that the product of the volume of a gas times its pressure is a constant at a fixed temperature.

$$PV = k$$

where  $k$  is a constant.

Therefore, at a fixed temperature, the pressure will be inversely proportional to the volume. As pressure increases, volume decreases. The relationship shown below shows that a plot of pressure versus the reciprocal of the volume will be linear.

$$P = \frac{k}{V}$$

where  $k$  is a constant.

### Equipment Setup

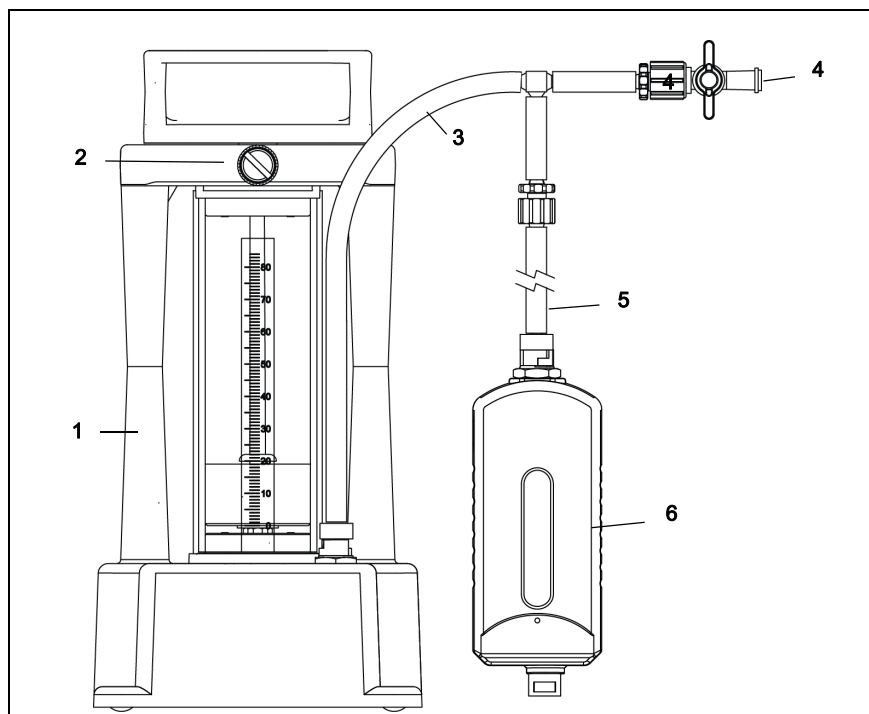

Setup Items	Setup Items
1. Heat Engine/Gas Law Apparatus	2. Locking Screw
3. Main Connector Tubing	4. Stopcock Valve
5. Pressure Sensor Adapter Tubing	6. PASCO Pressure Sensor

- Loosen the locking screw so that the piston can move freely up and down. Start with the piston at the top-most position. Tighten the thumbscrew momentarily to hold the piston in place.
  - You can record the position of the piston using the metric scale on the side of the cylinder.
- Attach the main connector tubing to the quick-release connector port on the Heat Engine. Add the stopcock valve to the end female Luer barb.
- Attach the pressure sensor adapter tubing to the side female Luer barb on the main connector tubing.
- Connect a PASCO Pressure Sensor to the pressure sensor adapter tubing.
- Close the valve on the stopcock.
- Connect the PASCO Pressure Sensor to a computing device.

## Software Setup

For information about collecting, recording, displaying and analyzing data, refer to the User's Guide or Online Help System for the data collection software.

- Start the PASCO data collection software and set up a display to record the pressure. Set up data recording for manual sampling (entering the data for position by hand).
- Set up a table that will allow you to manually enter the position of the piston. Create a calculation for the volume of the cylinder based on the height (position) of the piston. Add the calculation to your table.
  - NOTE: The volume in the cylinder depends on the piston position and the surface area of the piston. The piston's diameter is 32.5 millimeters.

## Data Collection

- Prepare to record pressure and the position of the piston. Loosen the locking screw. Press the platform down to a series of levels (such as every 5 mm) and manually record the position of the piston in the table. Watch the value of the pressure. (NOTE: Keep the pressure under 340 kilopascals (kPa) to minimize the chance of air leaking around the piston.)
- Stop recording data when the pressure reaches 120 kPa.

## Analysis

Use the data collection software to set up a graph of volume versus the reciprocal (inverse) of the pressure.

## Question

How well does your graph of volume versus the reciprocal of the pressure support the idea that the volume of a gas at constant temperature is inversely proportional to the pressure of the gas?

## Experiment 3: Combined Gas Law (Gay-Lussac's)

Equipment Needed	
PASCO Interface and Data Collection Software	Hot plate
PASCO Temperature Sensor	Pyrex beaker
PASCO Pressure Sensor	Water

The Heat Engine is not used for this activity.

### Introduction

Charles's Law states that volume is proportional to temperature ( $V \propto T$ ), and Boyle's Law states that volume is proportional to the reciprocal of pressure ( $V \propto 1/P$ ) where  $\alpha$  is a symbol for proportionality. Combining the two statements gives the following:

$$P = \frac{kT}{V}$$

where  $k$  is a constant.

The combined gas law predicts that, for a given mass of gas, if volume ( $V$ ) is held constant, pressure ( $P$ ) is directly proportional to temperature ( $T$ ).

### Equipment Setup

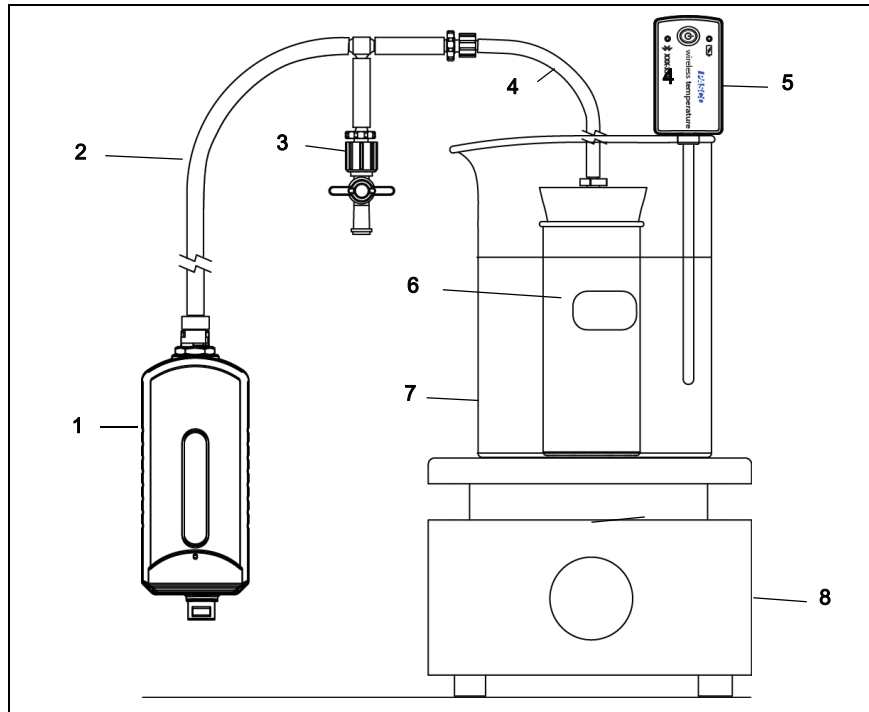

Setup Items	Setup Items
1. PASCO Pressure Sensor	2. Main Connector Tubing
3. Stopcock Valve	4. Rubber Stopper Tubing
5. PASCO Temperature Sensor	6. Thermal Can
7. Pyrex Beaker with Water	8. Hot Plate

1. Attach the main connector tubing to the quick-release connector port on a PASCO Pressure Sensor. Add the stopcock valve to the side female Luer barb.
2. Connect the PASCO Pressure Sensor to a computing device.
3. Attach the rubber stopper tubing to the end female Luer barb on the main connector tubing. Put the rubber stopper firmly into the thermal can.
4. Close the valve on the stopcock.
5. Connect the PASCO Temperature Sensor to a computing device.
6. Add cool water to the beaker and place the beaker on the hot plate. Put the sensor probe into the hot water, but do not let the tip of the probe touch the bottom of the container.
7. Place the thermal can into the beaker. Turn on the hot plate.

### Software Setup and Data Collection

For information about collecting, recording, displaying and analyzing data, refer to the User's Guide or Online Help System for the data collection software.

1. Start the PASCO data collection software
2. Set up a graph display to record the pressure and the temperature.
3. Record the pressure and temperature as the water warms up. Stop before the water boils.

### Analysis

Use the data collection software to determine if the graph of pressure versus temperature is linear.

### Question

How well does your graph of pressure versus temperature support the idea that the pressure of a gas at constant volume is directly proportional to the temperature of the gas?

## Experiment 4: Heat Engine Cycle

Equipment Needed	
Heat Engine/Gas Law Apparatus	Mass and Hanger Set
PASCO Interface and Data Collection Software	90 cm Steel Rod
PASCO Dual Pressure Sensor	Large Rod Stand
PASCO Rotary Motion Sensor OR	Thread
PASCO Motion Sensor	Plastic Containers (set of 2)

### Introduction

A heat engine is a device that does work by extracting thermal energy from a hot reservoir and exhausting thermal energy to a cold reservoir. In this case, the heat engine consists of the air inside a metal cylinder. The air expands when the cylinder is put into hot water. The expanding air pushes on a piston and does work by lifting a mass. The heat engine cycle is then completed when the cylinder is put into cold water, and the air pressure and volume return to the starting values.

The heat engine in this experiment will go through a four-stage expansion and compression cycle and do mechanical work by lifting a 200 gram mass from one height to another. Verify that the mechanical work done in lifting a mass,  $m$ , through a vertical distance,  $y$ , is equal to the net thermodynamic work done during the cycle as determined by finding the enclosed area on a pressure versus volume (P-V) diagram. Compare the mechanical work,  $ma_y$ , with the work from a heat engine as a function of pressure and volume changes give by the following expression.

$$W_{\text{net}} = \oint P dV$$

You can prove mathematically that this relationship holds, and the experimental verification allows you to become familiar with the operation of a real heat engine.

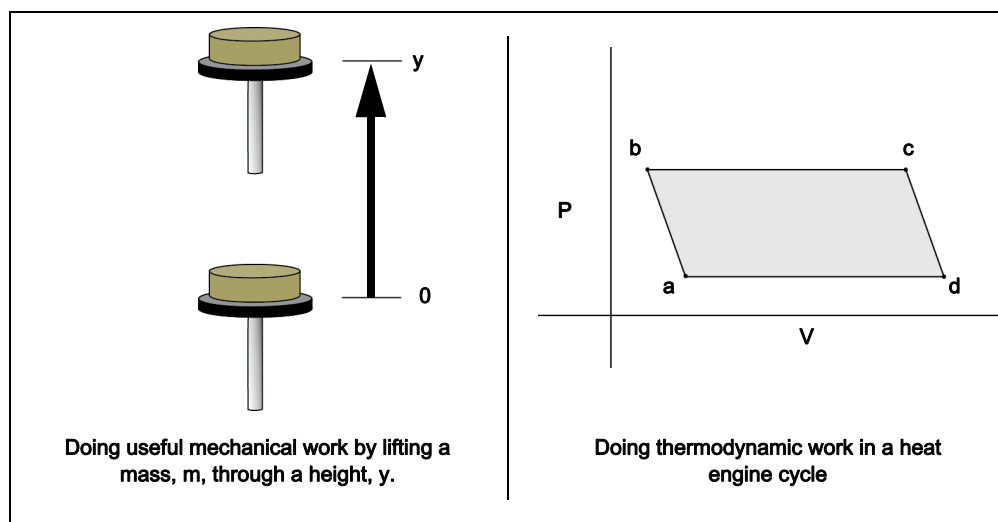

The PASCO Heat Engine/Gas Law Apparatus consists of a hollow cylinder with a low friction graphite piston that can move along the axis of the cylinder. The piston has a platform attached to it for lifting a mass. A metal can

sealed with a rubber stopper connects through flexible tubing to the Heat Engine/Gas Law Apparatus. A PASCO Pressure Sensor also connects to the flexible tubing. A PASCO Rotary Motion Sensor or PASCO Motion Sensor measures the position of the platform as it moves up or down.

## Theory of Operation

If the temperature of the air trapped inside the piston, metal can, and tubing increases, the volume will increase, causing the piston to lift the platform. You can increase the volume of the trapped air by immersing the metal can in hot water. When the platform has been lifted a distance,  $y$ , the mass is removed from the platform. The platform should then rise a bit more because the pressure on the cylinder of gas is decreased. Finally, the volume of the air will decrease when the metal can is immersed in cold water. This causes the platform to drop to its original position.

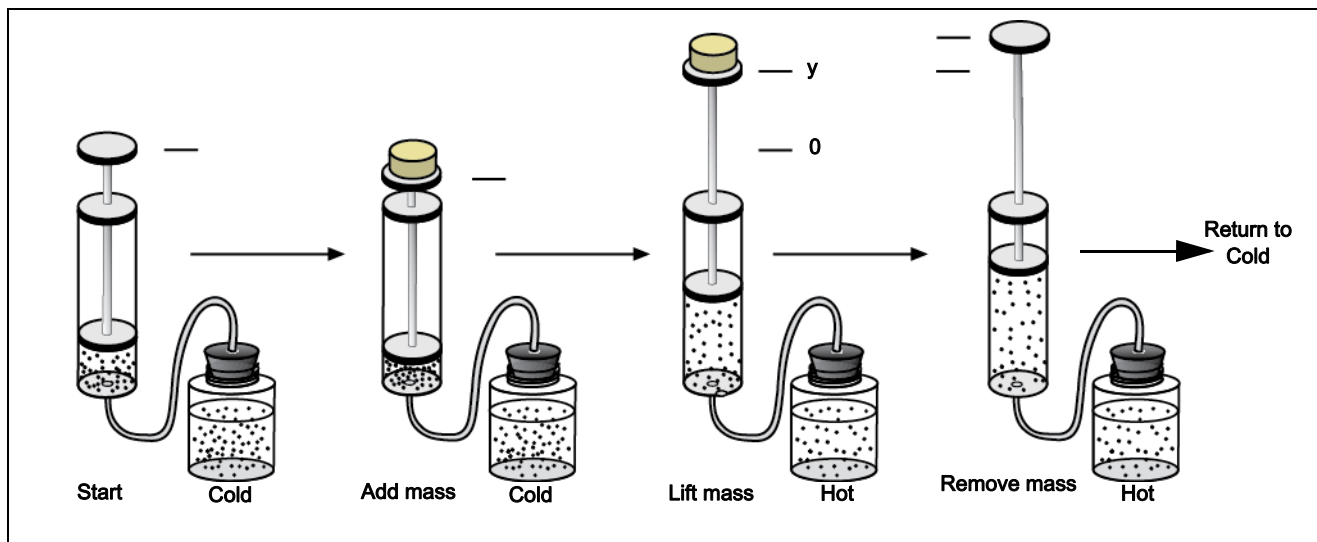

## Equipment Setup

1. Assemble a base and support rod. Place the Heat Engine rod clamp mount onto the support rod. Position the Heat Engine close to the bottom of the support rod and tighten the thumbscrew of the rod clamp mount.
2. Attach a PASCO Rotary Motion Sensor at the top of the support rod. Align the medium groove of the pulley on the sensor so a string coming from the center of the Heat Engine mass platform can pass over the groove of the pulley.
3. Select a mass hanger and add masses to it so the total mass is 48.5 grams. (The mass hanger and masses serves as a counterweight for the mass platform.)
4. Attach a thread to the hole in the top of the mass platform. Pass the thread over the medium groove of the Rotary Motion Sensor pulley and attach the mass hanger and masses to the thread.
5. Connect the PASCO Rotary Motion Sensor to a computing device.

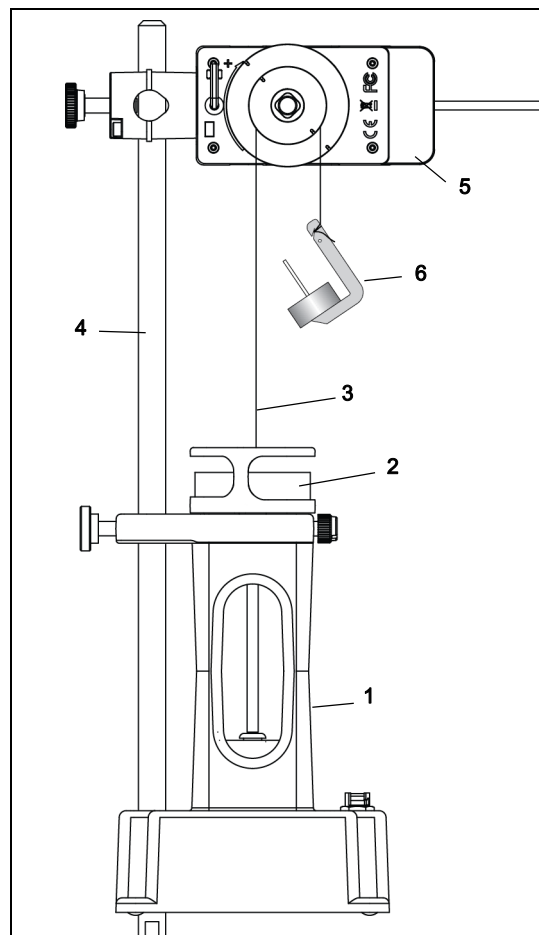

Setup Items	Setup Items
1. Heat Engine	2. 200 gram Mass
3. Thread	4. Support Rod
5. PASCO Rotary Motion Sensor	6. Mass Hanger and Masses

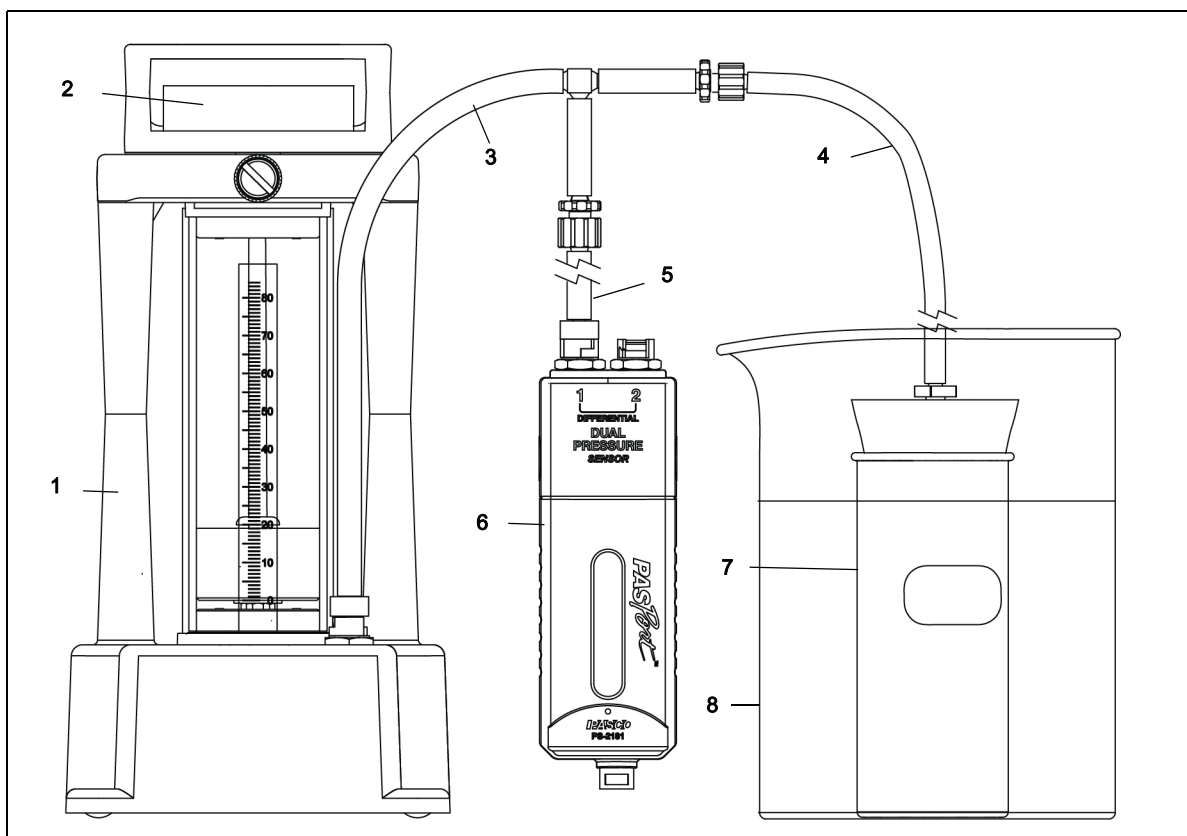

Setup Items	Setup Items
1. Heat Engine	2. 200 gram Mass
3. Main Connector Tubing	4. Rubber Stopper Tubing
5. Pressure Sensor Adapter Tubing	6. PASCO Dual Pressure Sensor
7. Thermal Can	8. Container* (one of two)

\*You also need hot water (about 80°C) for one container and cool water for the second container.

6. Connect the main connector tubing to the quick-release connector port on the base of the Heat Engine.
7. Connect the rubber stopper tubing to the end female Luer barb on the main connector tubing.
8. Connect the pressure sensor adapter tubing to the side female Luer barb on the main connector tubing.
9. Attach the PASCO Pressure Sensor to the quick-release connector on the end of the adapter tubing.
10. Connect the PASCO Pressure Sensor to a computing device.

Before taking measurements of the pressure and volume and height of lift with the heat engine, set it up and run through the cycle a few times to get used to its operation. A good way to start is to fill one container with room temperature water and the second container with hot water (about 80°C). The engine cycle is much easier to describe if the piston begins a little above the bottom of the cylinder. Therefore, raise the piston platform about 2 centimeters (cm). After the piston platform is raised, firmly insert the rubber stopper into the thermal can.

- Start with the can immersed in the cool water.
- Add the mass to the piston platform (a → b).
- Move the can to the hot water (b → c).
- After the mass is lifted, remove it from the platform (c → d).
- Return the can to the cool water (d → a).

After observing a few heat engine cycles, you should be able to describe each of the points, a, b, c, and d of a cycle.

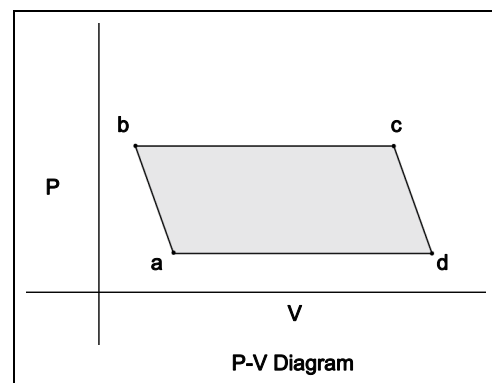

## Software Setup

For information about collecting, recording, displaying and analyzing data, refer to the User's Guide or Online Help System for the data collection software.

1. Start the PASCO data collection software.
2. Create a calculation of the volume of gas in the cylinder based on the radius of the cylinder,  $r$ , (1.625 cm) and the height of the piston,  $y$ , as measured by the PASCO sensor that records the position of the piston platform.
3. Set up a display to watch the pressure versus the calculated value of the volume of gas in the cylinder.

## Predictions

1. Transition (a → b): With the can in the cool water, what should happen to the height of the piston platform when you add the 200 gram mass?
2. Transition (b → c): What should happen when you place the thermal can into the container of hot water?
3. Transition (c → d): With the can still in the hot water, what should happen to the height of the piston platform when you remove the 200 gram mass?
4. Transition (d → a): What should happen when you place the thermal can back into the container of cool water?

## Data Collection and Observations

1. Record the starting position of the bottom of the piston in the cylinder.
2. Start recording pressure and position data with the data collection software.
3. With the thermal can in the cool water, add the 200 gram mass to the platform. Describe what happens. Is this what you predicted?
4. Move the thermal can to the hot water. Describe what happens. Is this what you predicted?
5. With the thermal can still in the hot water, remove the 200 gram mass from the platform. Describe what happens. Is this what you predicted?
6. Move the thermal can to the cool water. Describe what happens. Is this what you predicted? In particular, how does the volume of the air at the end of the cycle compare to the volume of air at the beginning? Are they the same, or did some air leak out?

7. End data recording.

## Analysis

Calculate the mechanical work done in lifting the mass,  $m$ , a vertical distance,  $y$ .

Convert the graph of pressure versus position to a graph of pressure versus volume. Use the graph of pressure versus volume to calculate the thermodynamic work done.

## Questions

How does the thermodynamic work compare to the mechanical work?

## Notes

Understanding the stages of the heat engine cycle on a P-V diagram is reasonably straightforward. However, it is difficult to use equations for adiabatic expansion and compression and the ideal gas law to determine the internal energy of the air throughout the cycle. There are several reasons for this. First, air is not an ideal gas. Second, the Heat Engine is not well insulated and heat travels through the cylinder wall. Therefore, the air in the thermal can and the air in the cylinder are probably not at the same temperature. Third, air does leak out around the piston. This means that the number of moles of air decreases over time. You can observe this by looking closely at the transition from d to a. The piston can actually end up in a lower position than it had at the beginning of the cycle. The Heat Engine does help the understanding of the actual stages in the operation of a real heat engine.

## Specifications

<b>Piston Diameter</b>	33.5 mm $\pm$ 0.1
<b>Mass of Piston and Platform</b>	48.5 g $\pm$ 0.6
<b>Maximum Pressure</b>	340 kPa

## More Information

See the PASCO catalog or web site for more information.

[www.pasco.com](http://www.pasco.com)

## Technical Support

For assistance with any PASCO product, contact PASCO at:

<b>Address:</b>	PASCO scientific 10101 Foothills Blvd. Roseville, CA 95747-7100
<b>Phone:</b>	916-786-3800 (worldwide) 800-772-8700 (U.S.)
<b>Web:</b>	<a href="http://www.pasco.com">www.pasco.com</a>
<b>Email:</b>	<a href="mailto:support@pasco.com">support@pasco.com</a>

### Limited Warranty

For a description of the product warranty, see the PASCO catalog or [www.pasco.com/legal](http://www.pasco.com/legal).

### Copyright

This document is copyrighted with all rights reserved. Permission is granted to non-profit educational institutions for reproduction of any part of this manual, providing the reproductions are used only in their laboratories and classrooms, and are not sold for profit. Reproduction under any other circumstances, without the written consent of PASCO scientific, is prohibited. Version: 2016-05-04.

### Trademarks

PASCO, PASCO scientific, PASCO Capstone, SPARK SLS, SPARKvue and PASPORT are trademarks or registered trademarks of PASCO scientific, in the United States and/or in other countries. All other brands, products, or service names are or may be trademarks or service marks of, and are used to identify, products or services of, their respective owners. For more information visit [www.pasco.com/legal](http://www.pasco.com/legal).

